

Automated 3D Surface Contact for Nastran FEA

CONTENT

Introduction	1
Examples	
Lens Mount	2
Hitch Assembly	4
Lug Assembly	6
Heat Transfer	9
Verification	10

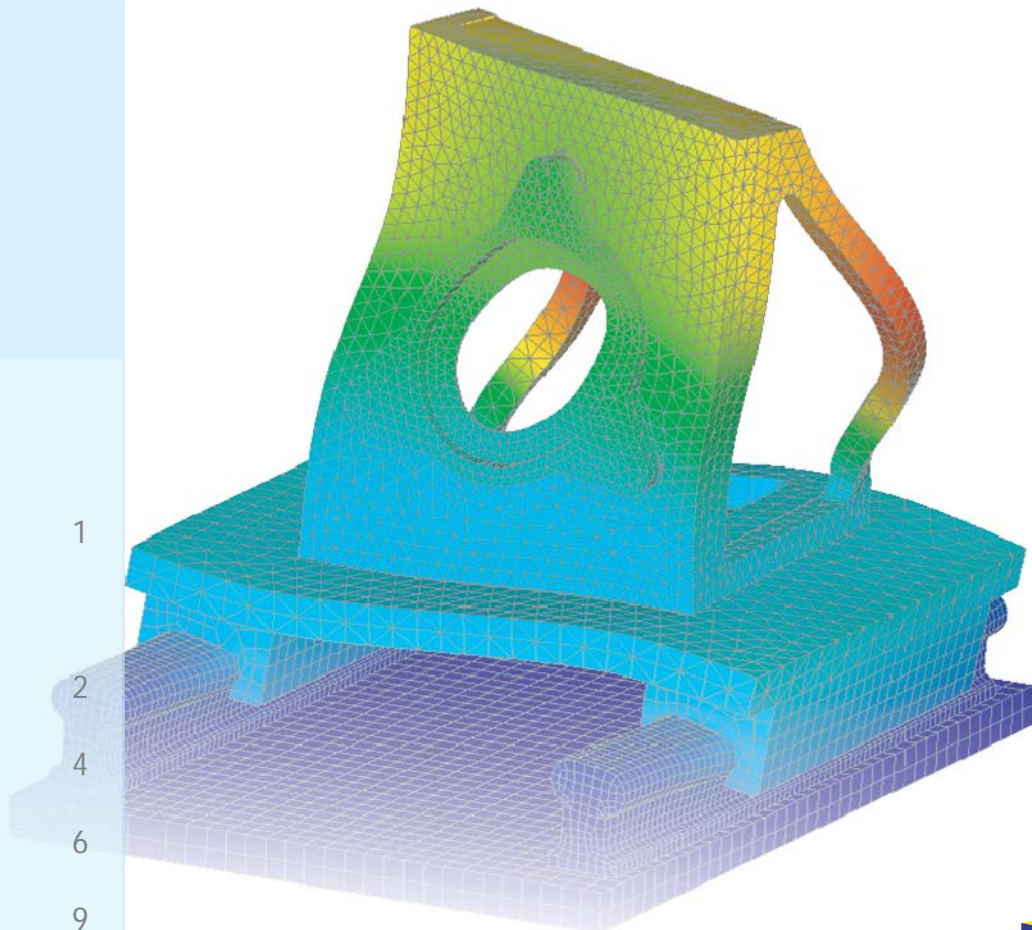

1. Introduction

NEiNastran V9 adds a powerful new feature that allows automatic surface contact generation (ASCG) between discontinuous bodies. This feature is ideally suited for models in which the contact areas are initially touching and where little sliding is expected.

The automated surface contact generation works in three phases. First the user defines parameters such as which elements should be considered for each contact pair generated (the default is all solid and shell elements in the model), what the near tolerance is for objects to be considered in contact with each other, and the type of contact to be generated (i.e., general, welded, bi-directional sliding, or rough). Using these user defined parameters, a region of elements is considered. The default would be all solid and shell elements in the model. The first phase consists of identifying the external surfaces of these elements. For shells it would be the entire element. For solids it would be any exterior surface. The second phase then looks for grid points that are positioned on or near and above (within the user defined tolerance) of each surface. The third phase eliminates invalid contact scenarios by considering surface normals. It is important that surfaces that are to be welded are not offset and that shell normals are oriented properly.

2. Parameters

NEiNastran uses two methods for setting up ASCG which are both described below:

Case Control Command Format

CONTACTGEN, PTYPE, SET ID, SFACT, FSTIF, MU, MAXAD, W0, TMAX

Where,

PTYPE is the contact type: 1=general, 2=weld, 3=bi-directional slide, 4=rough (default = 2).

SET ID is an existing or generated element output set id (default = all elements).

SFACT is the stiffness scaling factor for penetration (default = 1.0).

FSTIF is the transverse stiffness for stick.

MU is the friction coefficient (default = 0.0).

MAXAD is the maximum normal activation distance (default is 1.0E-4 x model reference dimension).

W0 is the closed position tolerance (default = 0.0).

TMAX is the maximum allowable penetration for displacement based penalty stiffness updating.

See the NEiNastran Reference Manual, BSCONP Bulk Data entry for more information on **SFACT, FSTIF, MU, W0, and TMAX**. **MAXAD** is further described below.

Model Parameter Format

PARAM, CONTACTGEN, PTYPE

PARAM, CONTACTTOL, MAXAD

Where,

PTYPE is the contact type: 1=general, 2=weld, 3=bi-directional slide, 4=rough (default = 2).

MAXAD is the maximum normal activation distance (default is $1.0E-4$ x model reference dimension).

MAXAD is the contact surface normal tolerance for generating a contact segment/element. A recommended value is a distance approximately 10% larger than the largest gap you want to be recognized as contact (or welded). Note that this parameter is optional (although recommended) and if omitted will be internally calculated by NEiNastran. The default value is calculated by first creating a bounding box for the entire model and then evaluating the distance between the largest diagonal in the box (from one corner to another). This reference dimension is then multiplied by $1.0E-04$ to get the **MAXAD** value used. User specified values are actual distance and are not normalized. For some models (i.e., very large, very small, or with large gaps) the default **MAXAD** value may not be well suited, therefore it is recommended the analyst define this explicitly.

3. Examples

The models below show the wide variety of applications that ASCG can be used on.

3.1 Lens Mount

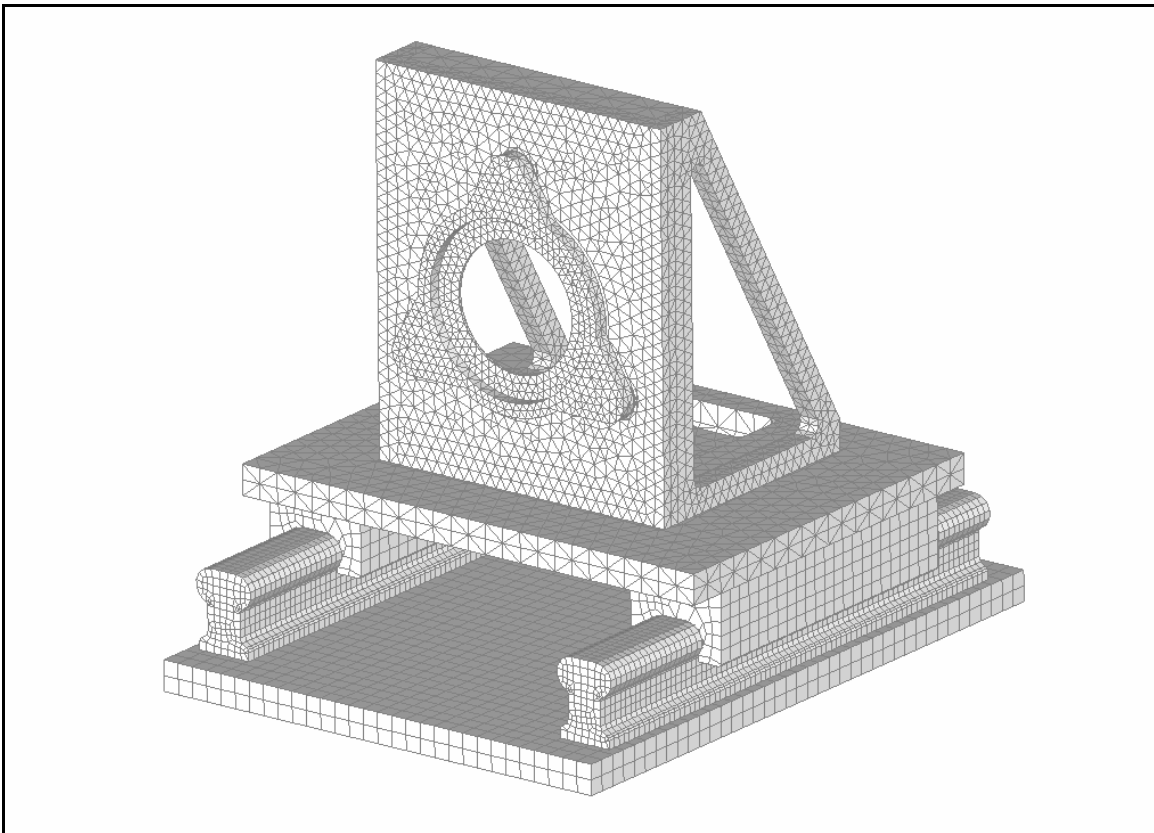

Figure 1. Meshed Lens Mount Assembly

The first example is an 11 part assembly of a lens mount (Figure 1). Due to complexities in geometry only some parts were able to be easily hex meshed, so a hybrid model was built with linear hex elements and parabolic tet elements. Since all the parts were meshed independently, areas of interest could be meshed with finer detail.

The part was setup with a body load of 10g's in the lateral direction with the based fully fixed. A linear static analysis was performed. ASCG was added by means of one case control command into the model as:

CONTACTGEN, 2

This will invoke ASCG in NEiNastran and setup the contact regions as welds. The picture in Figure 2 shows the (scaled) deformation results of the model using the ASCG feature:

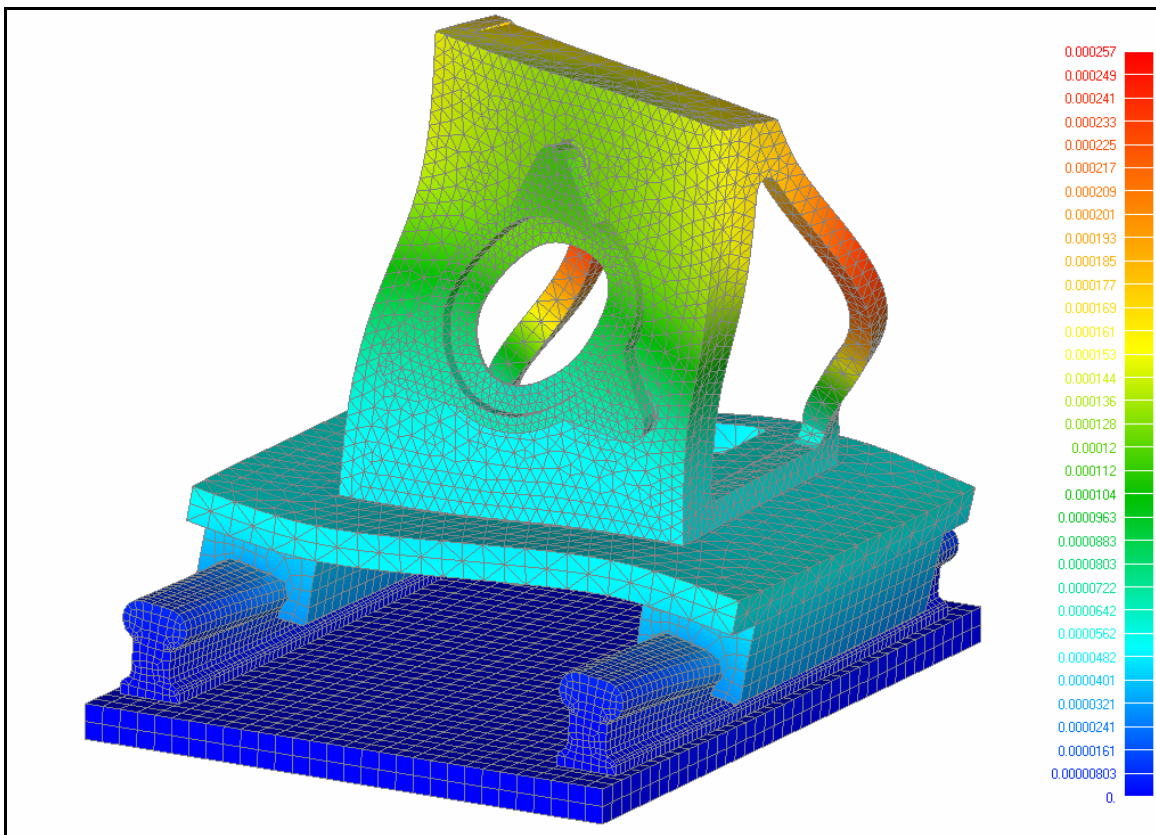

Figure 2. Scaled Deformation Results of Lens Assembly

3.2 Hitch Assembly

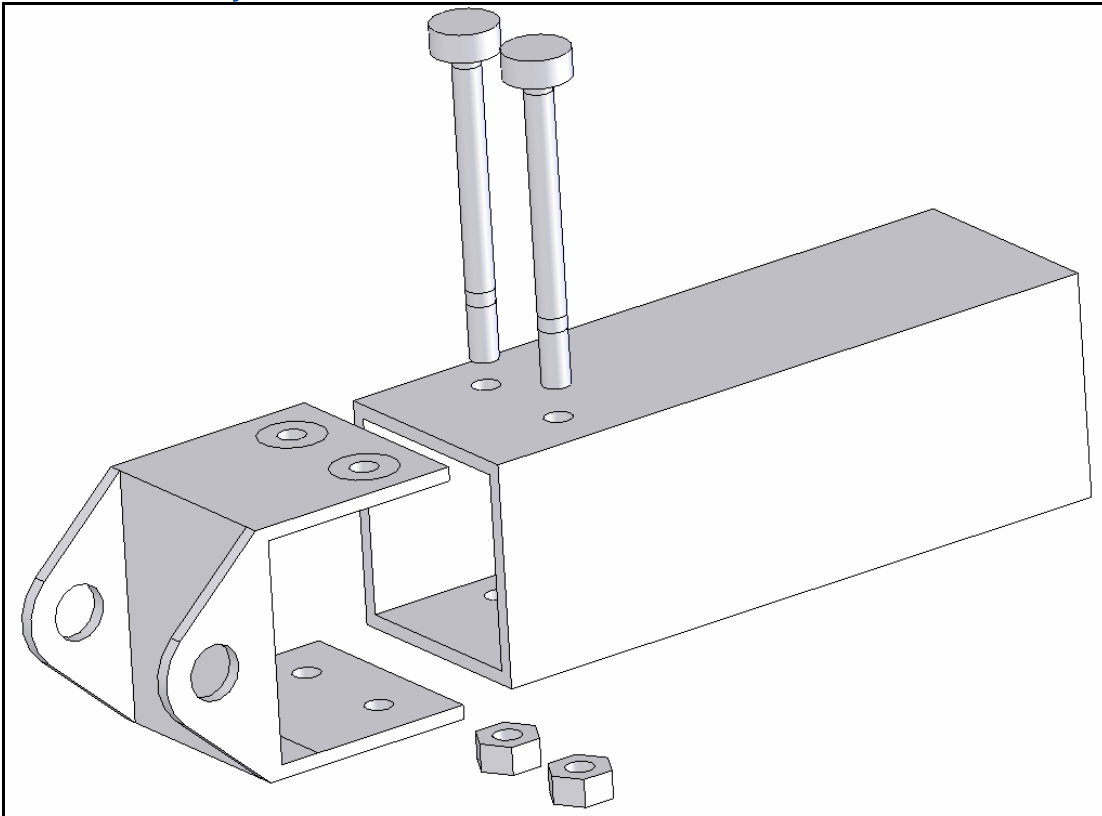

Figure 3. Exploded View of Hitch Assembly

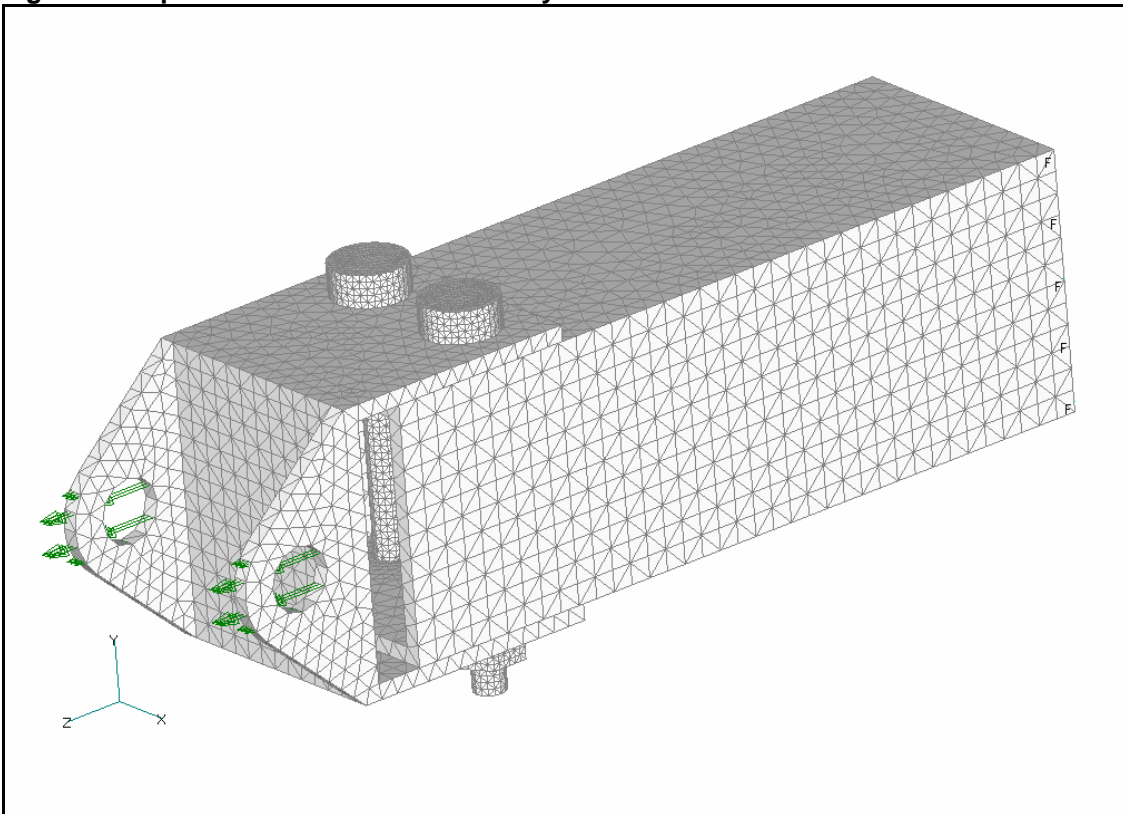

Figure 4. Meshed and loaded hitch assembly

The hitch assembly as seen in Figures 3 and 4 is a 6 part assembly. A linear analysis is performed with the back end fixed and a 10,000 lb load applied to the pin holes. By taking advantage of the bi-directional slide contact capability of NEiNastran, this part can be analyzed with good accuracy in a linear static analysis. All contacting areas will be bi-directional slides except for the nut/bolt interface. Since we want that area to be fully welded (to simulate the nuts engaged in the threads) we can simply create two sets (groups in the NEiNastran Modeler which would be exported as sets). This first set contains the nuts and bolts. The second set contains all the parts except the lower shafts of the bolts (where the nut would screw on). After exporting the model, two case control commands are added:

CONTACTGEN, 2, 1

This specifies ASCG to create welded contact for the elements in set 1 (nuts and bolts).

CONTACTGEN, 3, 2

This specifies ASCG to create bi-directional slides for the elements in set 2 (hitch and tube).

As you can see from Figures 5 and 6, the displacements show sliding between the two main bodies like you would see in a nonlinear free-contact analysis.

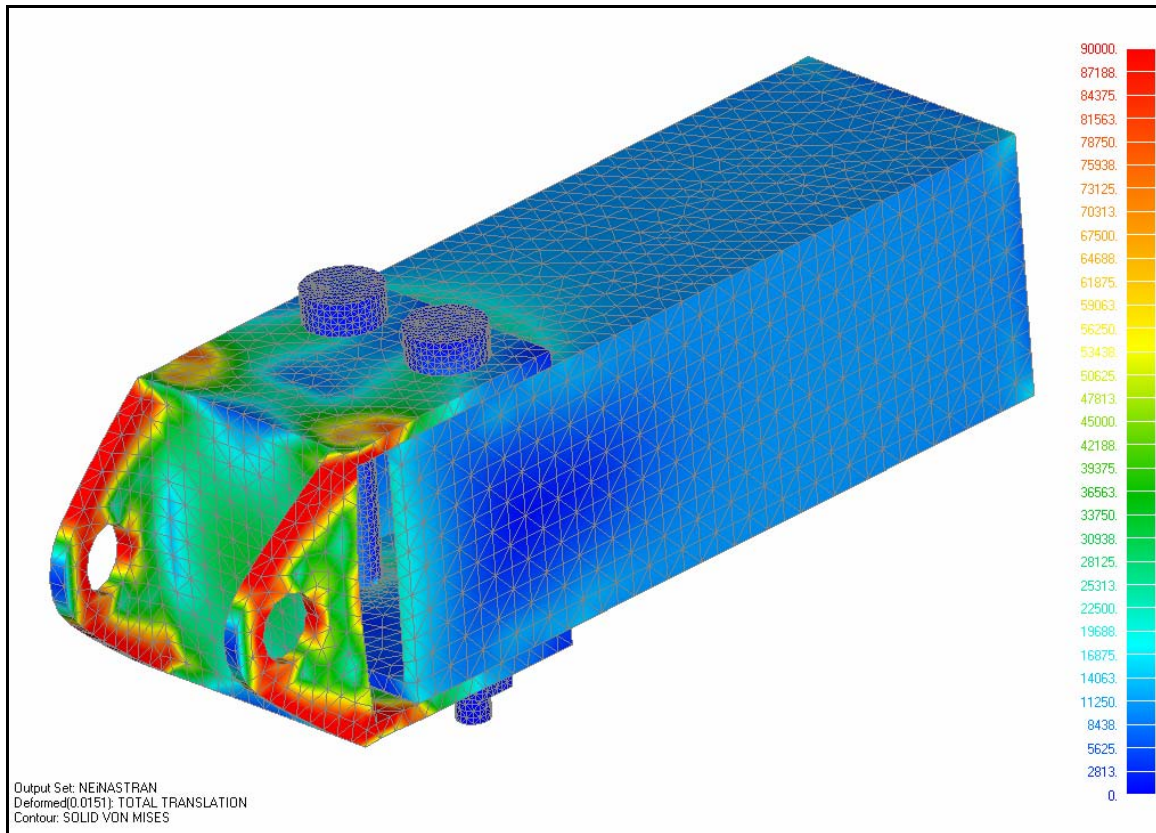

Figure 5. Solid Von Mises Stress Results of Hitch

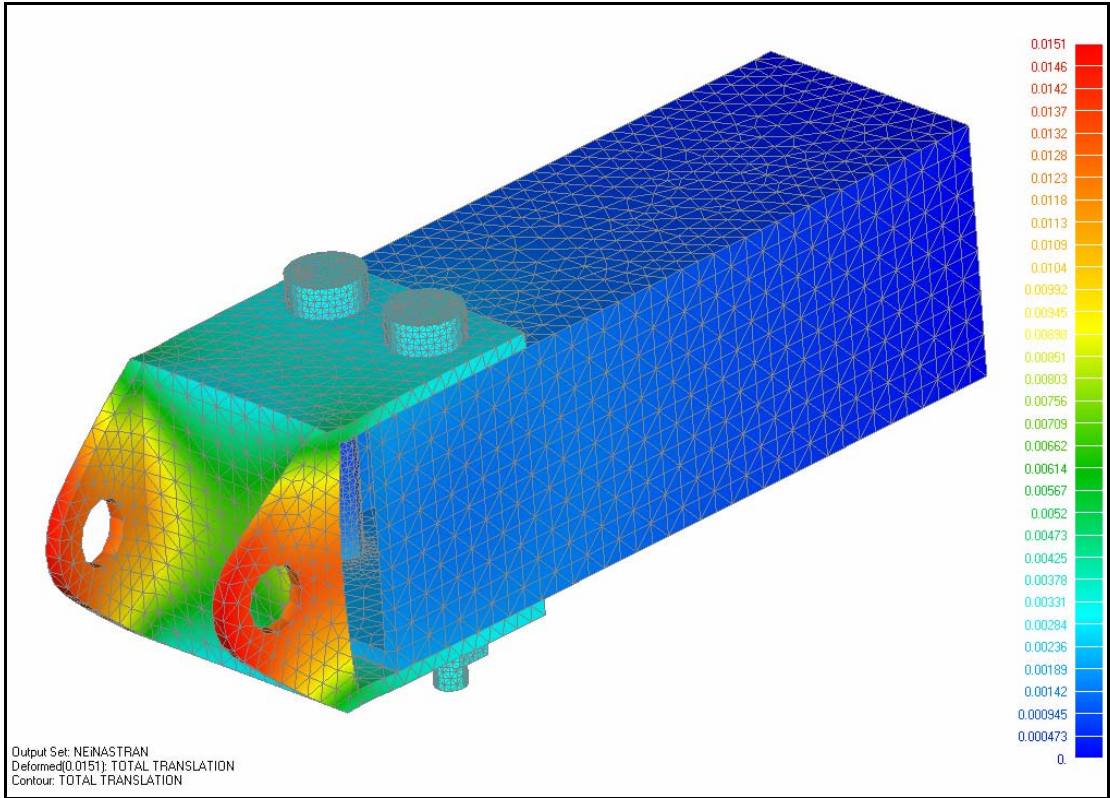

Figure 6. Deformation Results of Hitch. Notice the Sliding Taking Place Between the Shaft and Hitch.

3.3 Lug Assembly

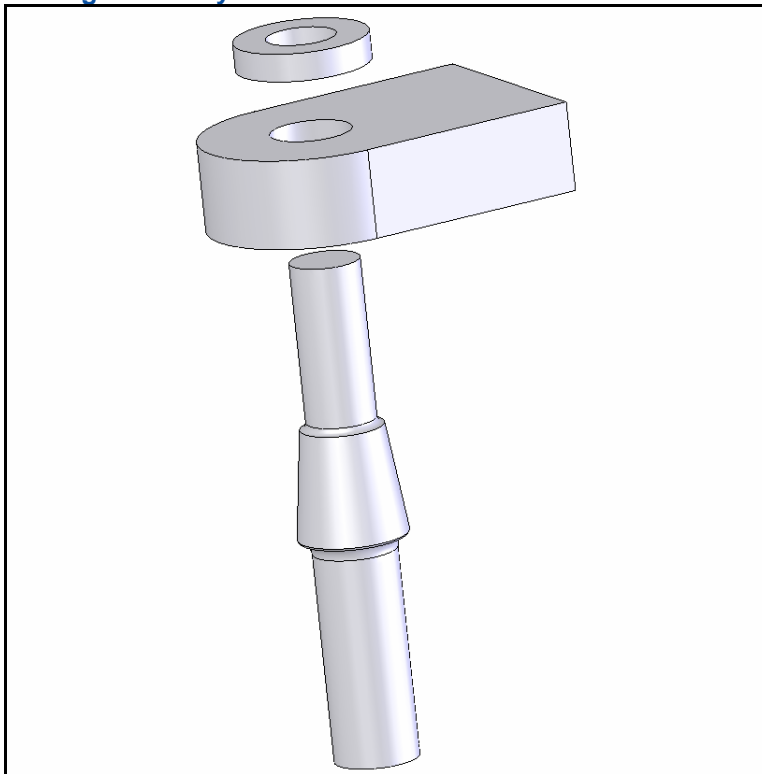

Figure 7. Exploded View of Lug Assembly.

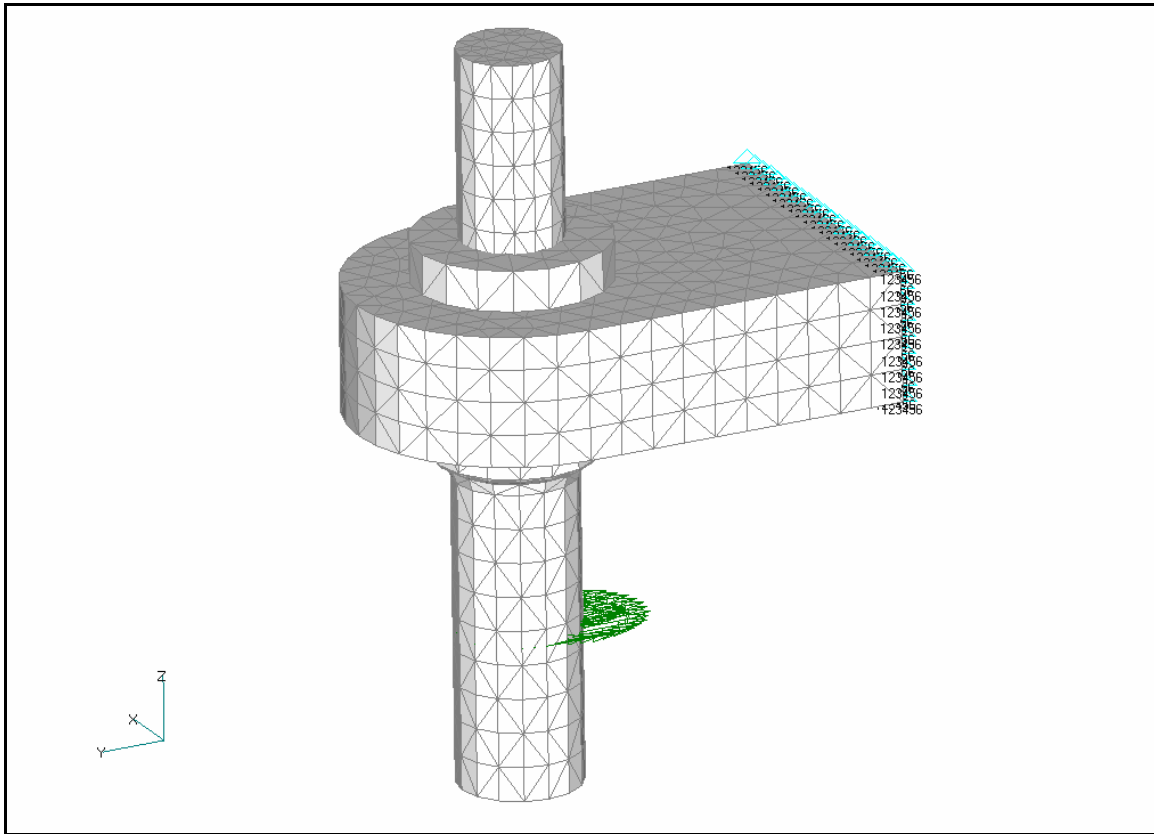

Figure 8. Meshed Lug Assembly.

The lug assembly as seen in Figures 7 and 8 contains 3 individual parts, namely, the lug, stud, and nut (modeled as an annular ring). There is a 1000 lb force applied in the negative Y direction. Due to the loading involved, there will be separation between the stud and lug. Because of this, a nonlinear analysis must be performed. There are two approaches that can be taken in generating the contact:

- 1) The first approach would be to setup the Stud and Nut as one set, and define that region as a weld for the ASCG. The other area would be the Stud to Lug contact and the Nut to Lug contact. That region would be created as set 2, and defined as free contact for the ASCG.
- 2) The other (easier) approach would be to define all the areas of contact as Rough Contact (PTYPE = 4 for the ASCG). Rough contact ensures no sliding between the contact surfaces, yet allows contact areas to open or separate. With the loading in mind and assuming little sliding will occur between the lug-stud and nut-lug interfaces, this method should provide accurate results.

For this example the second approach was used. A single line in the case control was added for the ASCG as follows:

CONTACTGEN, 4

As you can see from the results in Figures 9 and 10, separation between the lug and stud is visible as we would expect in a real world application.

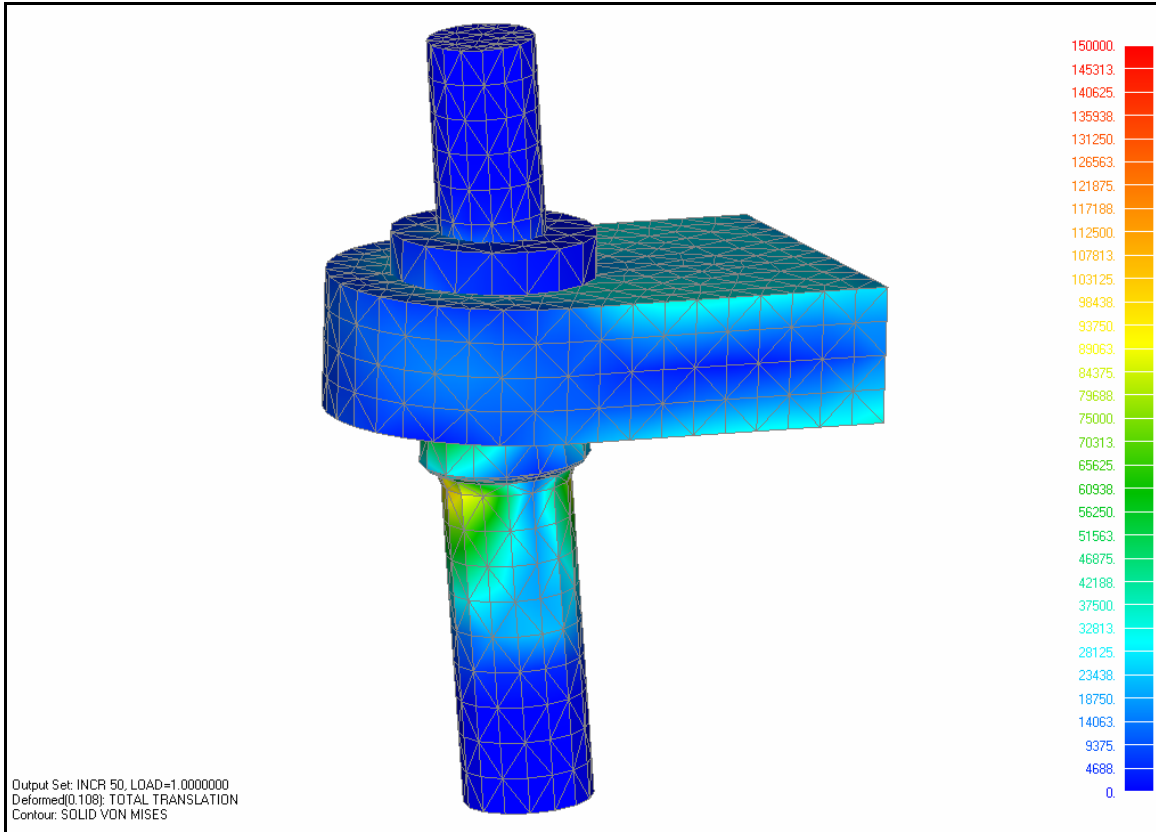

Figure 9. Lug Assembly Stress Results.

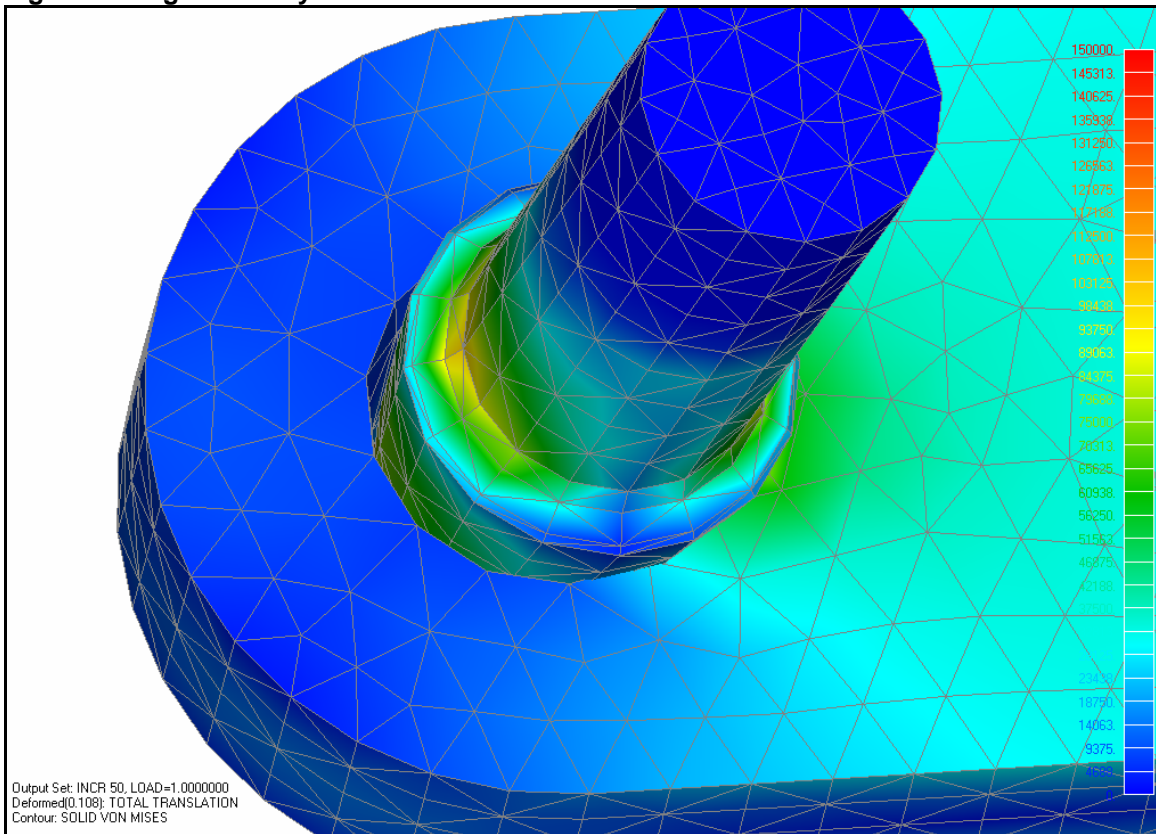

Figure 10. Underside of Stud Showing Separation Between Lug and Stud

3.4 Pan and Burner

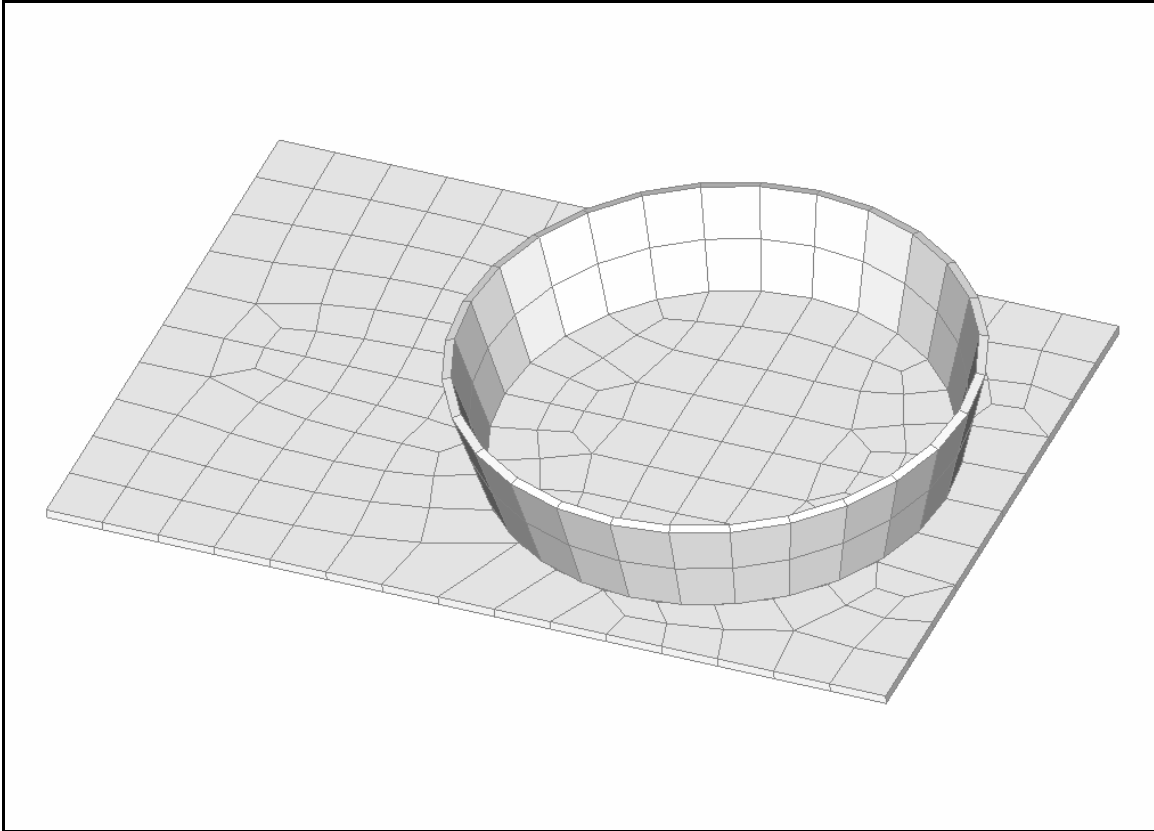

Figure 11. Pan and Burner Assembly.

In this example (Figure 11), we take one of the NEiNastran tutorials (Example Problem 7) which consists of a pan and cook top assembly in a steady state heat transfer analysis. In the tutorial the surface contact is setup manually, but using ASCG, there is no longer a need to manually create the contact. Instead, a line in the case control is added as follows:

CONTACTGEN, 2

No other modifications are required. The defaults in NEiNastran will treat surface contact as a conductor for heat transfer analysis. The results (Figure 12) show the same temperature as in the original tutorial.

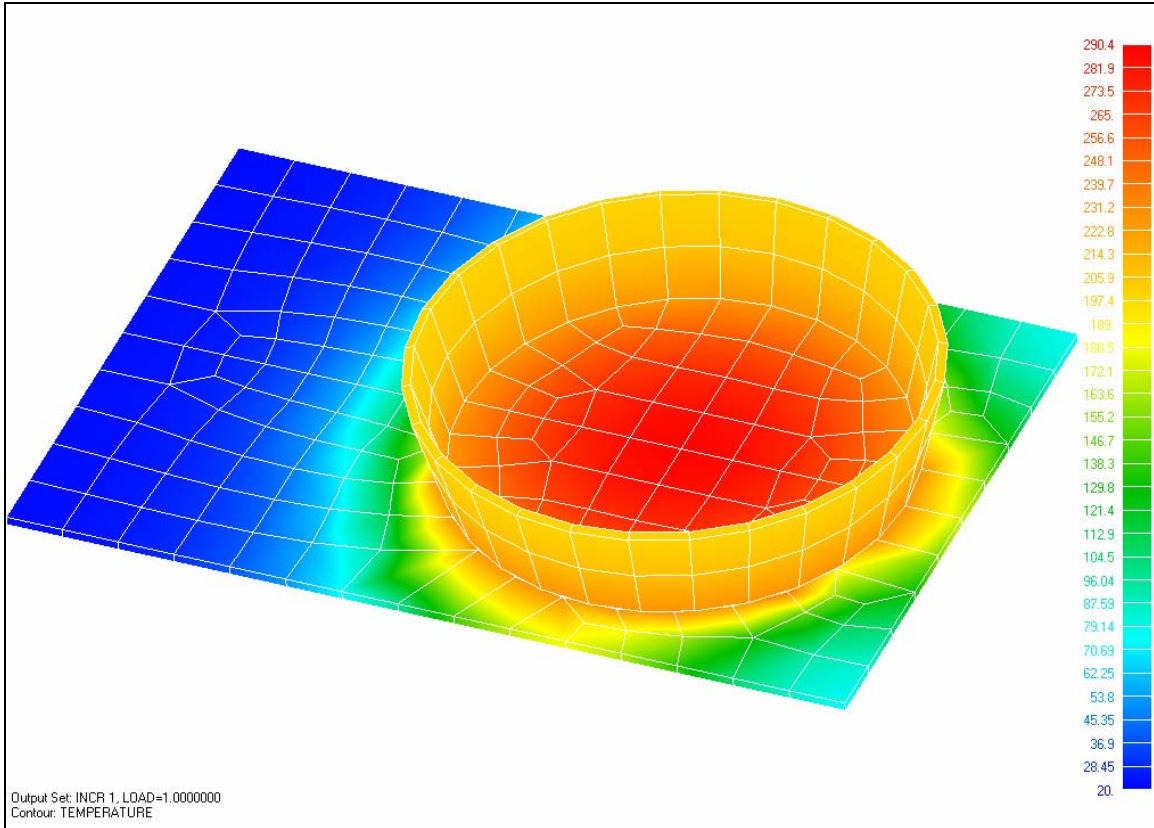

Figure 12. Pan and Burner Temperature Results.

4. Contact Verification

It is good practice to verify that the generated surface contact is in-line with what was intended. This can be accomplished by setting an output directive in the NEiNastran Editor (under Output Control Directives), called TRSLMODLDATA. Setting this to ON will generate a .BDF file (with the same name as the analysis file). This .bdf file will contain all the information that the .nas file has, but in addition it will have the surface contact that was created in the ASCG. This .bdf file can be imported into the NEiNastran Modeler (File-Import-Analysis Model). After import, the quick options can be used to turn off all entities except for the contact. Figure14 shows the contact that was generated from the lug assembly (section 3.3).

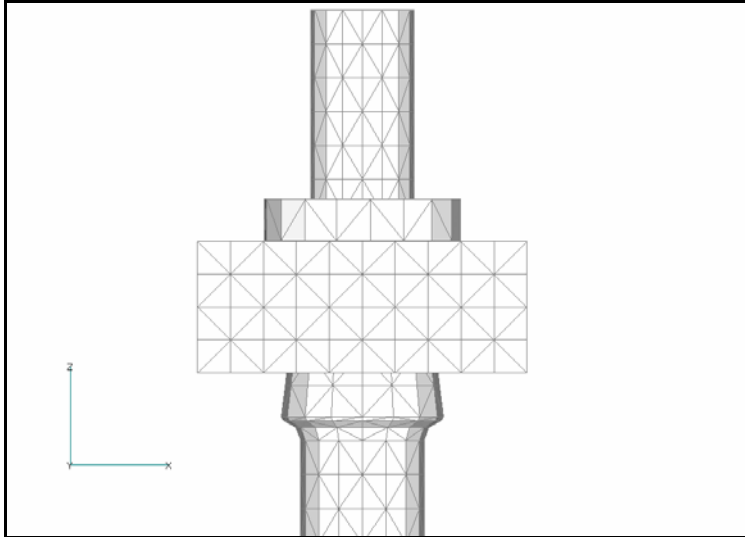

Figure 13. Side View of Lug Assembly.

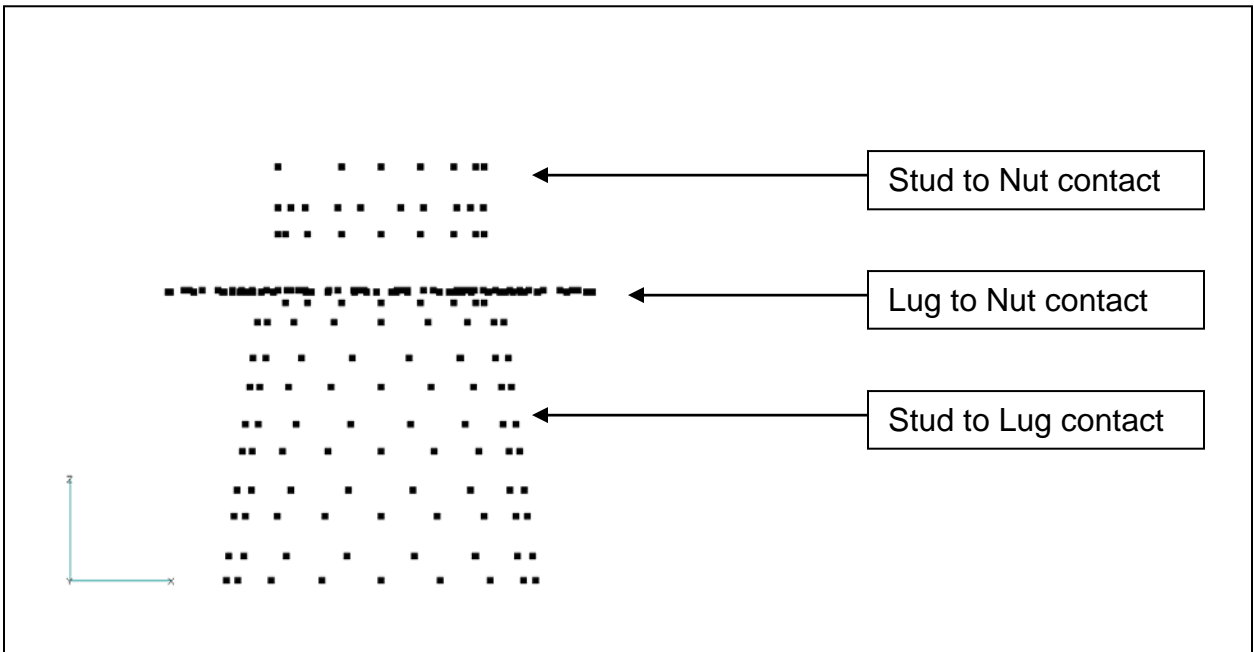

Figure 14. Viewing the Contact Areas in the NEiNastran Modeler (Same Orientation as Figure 13).

Noran Engineering, Inc.

USA HEADQUARTERS

Noran Engineering, Inc
5555 Garden Grove Blvd., Ste 300,
Westminster, CA 92683-1886, USA
Phone: 1.714.899.1220
Fax: 1.714.899.1369
E-mail: info@noraneng.com
Website: www.nenastran.com

EUROPE

SmartCAE
Piazza della Gualchierina, 9
59100 Prato, ITALY
Phone: +39.0.574.404.642
Fax: +39.0.574.401.265
E-mail: info@smartcae.com
Website: www.smartcae.com

ASIA/PACIFIC

Digital Solutions
Kyoei Nakasuji Bldg, 3-7-18
Nakasuji, Asaminami-ku
Hiroshima, 731-0122, JAPAN
Phone: +81.82.831.1190
Fax: +81.82.831.1193
E-mail: post@digital-sol.co.jp
Website: www.digital-sol.co.jp

